

REV.	DESCRIPTION	DATE
A	RELEASED	Sep. 26, 2018
B	PACKETING MODIFY	Aug. 27, 2020
C	ADD PLATING OPTIONS	Oct. 06, 2020

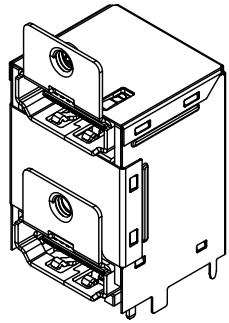

3D VIEW

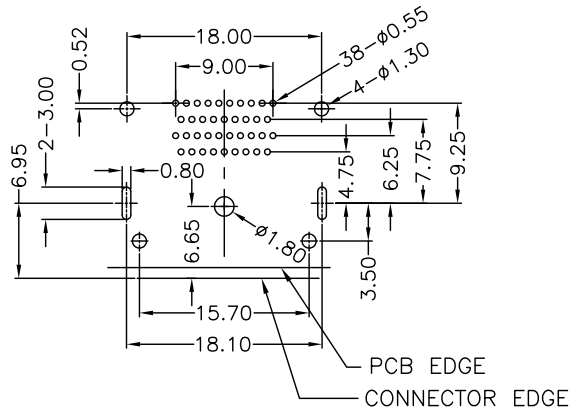
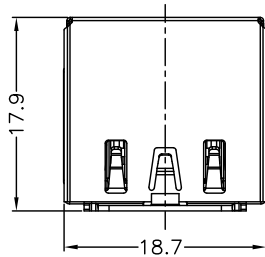

RECOMMEND P.C.B. LAYOUT  
TOLERANCE: ±0.05mm (TOP VIEW)

**MATERIALS**

- HOUSING : LCP (UL 94V-0), BLACK.
- TERMINAL : C2680 (t=0.20mm), GOLD PLATED ON CONTACT AREA, TIN 80u" PLATED ON SOLDER TAIL, UNDER NICKEL 50u" PLATED OVER ALL.
- HDMI SHELL : C2680 (t=0.50mm), NICKEL PLATING.
- BAFFLE : SUS304 (t=0.20mm), NICKEL PLATING.
- SHIELD : SUS304 (t=0.20mm), WELDING NICKEL PLATING.

**SPECIFICATION**

- CURRENT RATING : 0.5 AMP. MAX.
- RATING VOLTAGE : 40V AC
- DIELECTRIC WITHSTANDING VOLTAGE : 500V AC R.M.S. FOR ONE MINUTE.
- INSULATION RESISTANCE : 100M OHMS MIN.
- CONTACT RESISTANCE : 30m OHMS MAX.
- MATING FORCE : 4.5Kgf MAX.
- UNMATING FORCE : 1.0Kgf MIN.
- DURABILITY : 10,000 CYCLES.
- OPERATING TEMPERATURE : -20°C TO +85°C.

**PART NUMBER INFORMATION :**

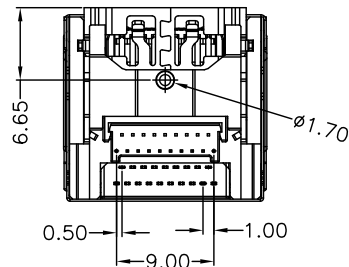
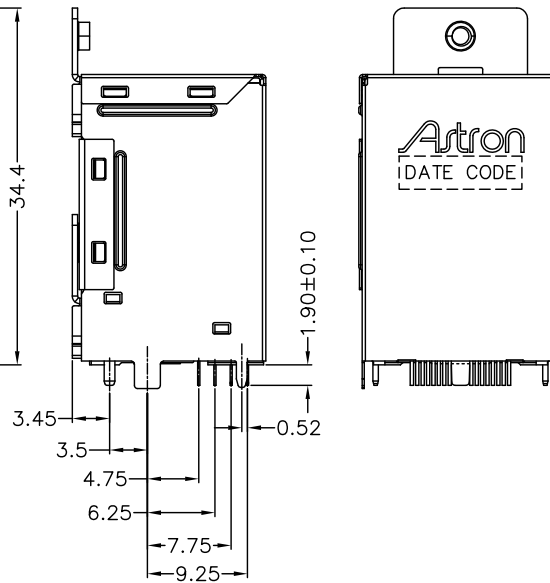
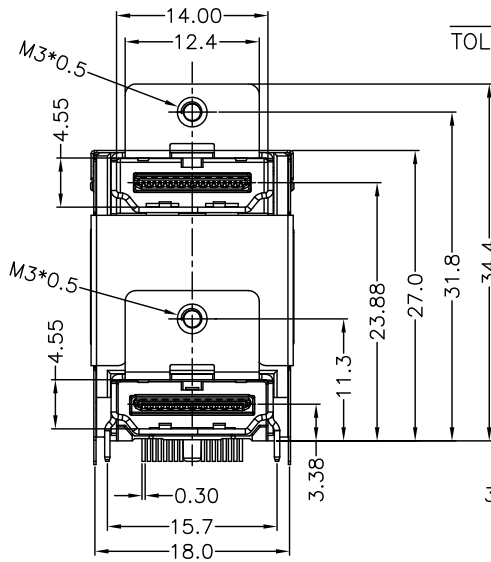
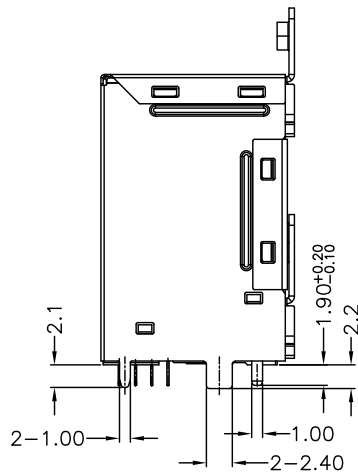
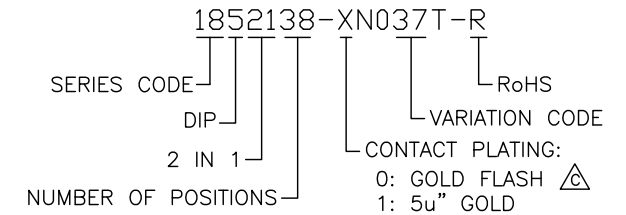

GENERAL TOLERANCE		DRAWER <i>LLJ</i>		 <b>ASTRON TECHNOLOGY CORP.</b>	
DIM.	.0 = ±0.20 .00 = ±0.15 .000 = ±X.XX	CHECK <i>ERP</i>			
ANG.	0° = ±3° .0° = ±X° .00° = ±X°	APP'D <i>ALAN</i>		NAME DUAL HDMI STACKED CONN WITH FLANGE	
3rd ANGLE PROJECTION		PRODUCT SPEC. -		PART NO. 1852138-XN037T-R	
SCALE NONE		SIZE A4	SHEET 1 OF 2	REV. C	C NO. 08031(T0166)

REV.	DESCRIPTION	DATE
A	RELEASED	Sep. 26, 2018
B	PACKETING MODIFY	Aug. 27, 2020
C	ADD PLATING OPTIONS	Oct. 06, 2020

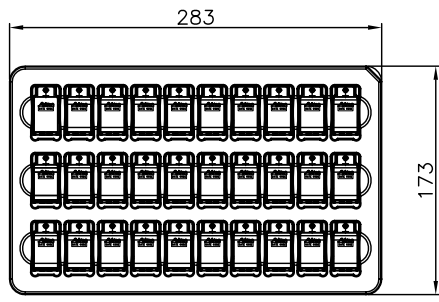

△ UP COVER

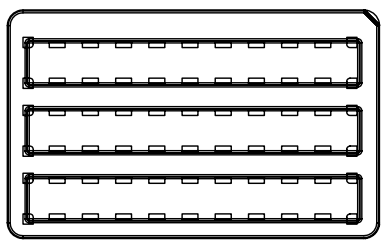

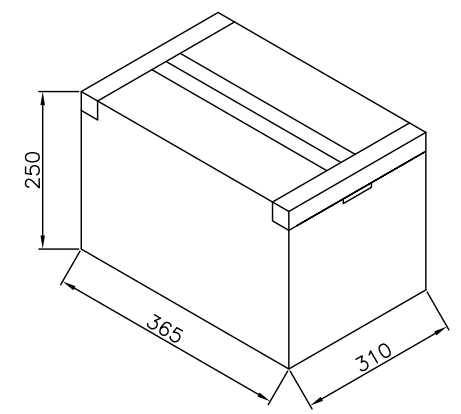
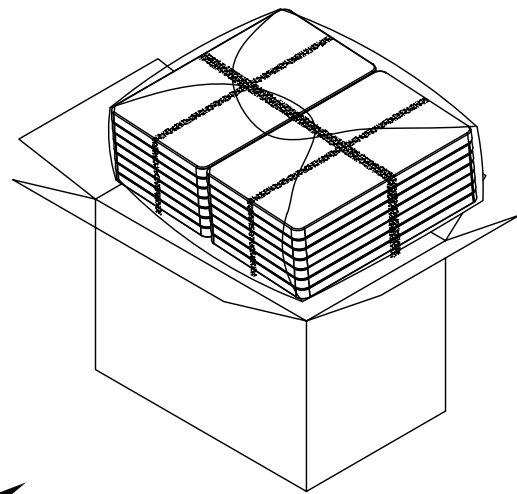

△ BOTTOM COVER

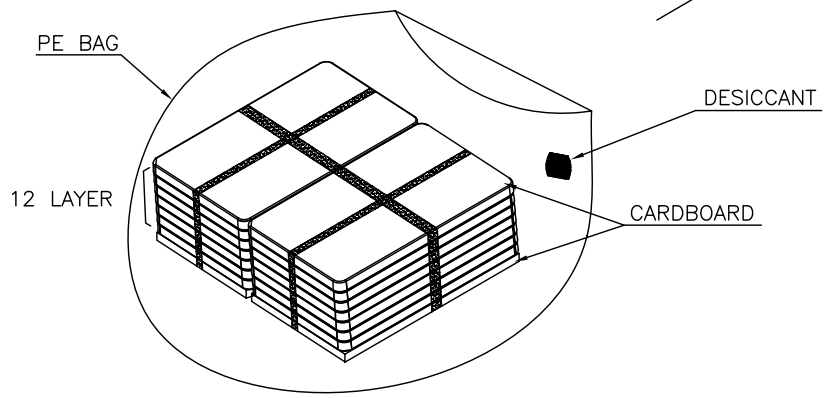

**PACKAGE :**

- 1. SIZE :  
 TRAY : 283 x 173 mm (LxW)  
 CARTON : 365 x 310 x 250 mm (LxWxH)
- 2. QUANTITY :  
 30 PCS / TRAY  
 24 TRAYS / CARTON = 720 PCS

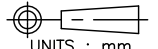

GENERAL TOLERANCE		DRAWER <i>LLJ</i>		 <b>ASTRON TECHNOLOGY CORP.</b>	
DIM. .0 = ±0.20 .00 = ±0.15 .000 = ±X.XX		CHECK <i>ERP</i>			
ANG. 0° = ±3° .0° = ±° .00° = ±X°		APP'D <i>ALAN</i>		NAME DUAL HDMI STACKED CONN WITH FLANGE	
3rd ANGLE PROJECTION		PRODUCT SPEC. -		PART NO. 1852138-XN037T-R	
 UNITS : mm		<b>CONFIDENTIAL</b>		08031(T0166)	
SCALE NONE	SIZE A4	SHEET 2 OF 2	REV. C	C NO.	