

REV.	DESCRIPTION	DATE
F	11'1229	Dec 28,2011
G	12'0526	May 28,2012
H	N17'03011	Mar 22,2017

### MATERIALS

- HOUSING: THERMOPLASTIC (UL 94V-0).
- TERMINAL: COPPER ALLOY,  
PLATING: GOLD PLATED ON CONTACT AREA,  
TIN PLATED ON SOLDER TAILS,  
NICKEL UNDER PLATED OVERALL.
- BOARD LOCK: COPPER ALLOY,  
PLATING: TIN PLATED OVER NICKEL.
- FRONT SHELL: SPCC, NICKEL PLATED OVERALL.
- RIVET: Zn ALLOY, NICKEL PLATED OVERALL.

### SPECIFICATION

- MATING FORCE: 4.5KG MAX.
- UNMATING FORCE: 1.0-4.0KG.
- DIELECTRIC WITHSTANDING VOLTAGE:  
500V AC R.M.S. FOR ONE MINUTE.
- INSULATION RESISTANCE:  
1000MΩ MIN AT 500V DC.
- CONTACT RESISTANCE: 30mΩ MAX.
- OPERATING TEMPERATURE : -25°C TO +85°C.

### PART NUMBER INFORMATION:

2560029-XWX-H

SERIES CODE | DIP | FEMALE | NUMBER OF POSITIONS | PLATING SEE TABLE

R: ROHS  
H: HALOGEN FREE

CHOICE:  
W1: HAVE COPPER FOIL; HOUSING BLACK  
W2: HAVE COPPER FOIL; HOUSING BEIGE  
W3: NO COPPER FOIL; HOUSING BLACK  
W4: NO COPPER FOIL; HOUSING BEIGE  
W5: HAVE COPPER FOIL; HOUSING BLACK  
SHELL SALT SPRAY FOR 24H

DESCRIPTION OF PLATING ON TERMINALS			
NO.	EXPLAIN	NO.	EXPLAIN
0	GOLD FLASH	3	GOLD 15u"
6	GOLD 30u"		

TOLERANCE .0=±0.30 .00=±0.20 .000=±0.10 ANG.=±3'	DRAWER <i>Duan</i>	 <b>Astron</b> ASTRON TECHNOLOGY CORP.
UNITS : mm	CHECK <i>Stony</i>	
SCALE NONE	APP'D <i>Stony</i>	NAME DVI FEMALE 24+5PIN NO BACK SHELL DIP TYPE
SIZE A5	PRODUCT SPEC. —	DRAW NO. R2560029-XWX-X
SHEET 1 OF 2	REV. H	

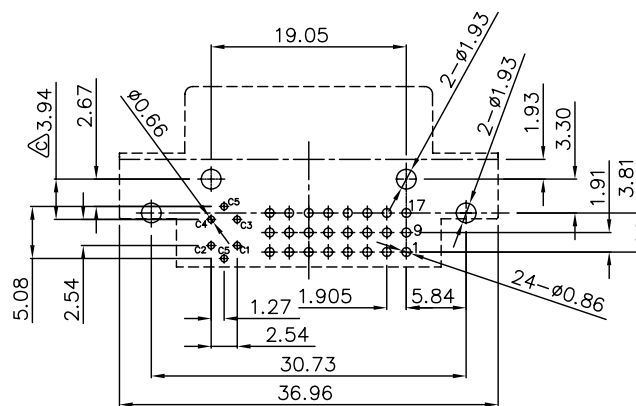
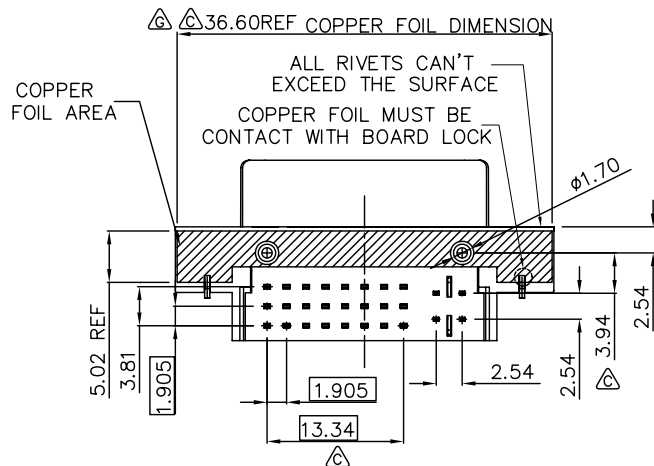
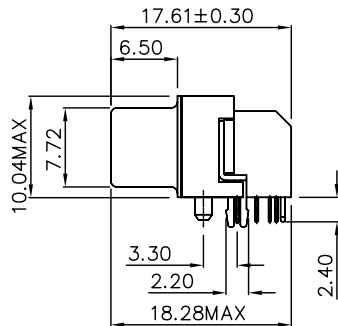
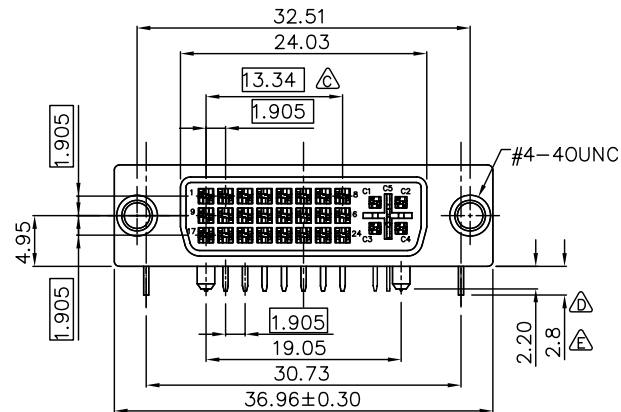

RECOMMEND PCB LAYOUT  
TOLERANCE: ±0.05  
TOP VIEW

REV.	DESCRIPTION	DATE
F	11'1229	Dec 28,2011
G	12'0526	May 28,2012
H	N17'03011	Mar 22,2017

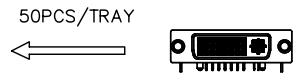
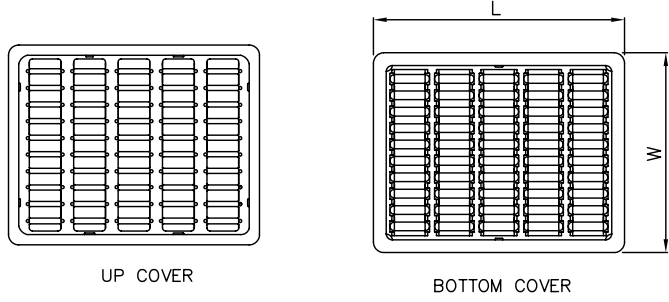

**NOTES:**  
**MATERIAL:**  
 1. TRAY: PVC  
**QUANTITY:**  
 1. 1000 PCS/CARTON  
**DIMENSION:**  
 1. TRAY SIZE : 245\*195  
 2. CARTON SIZE : 405\*255\*230

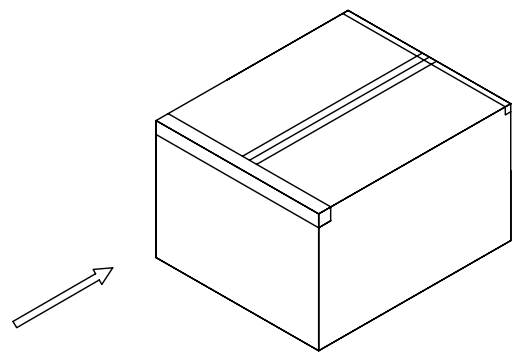
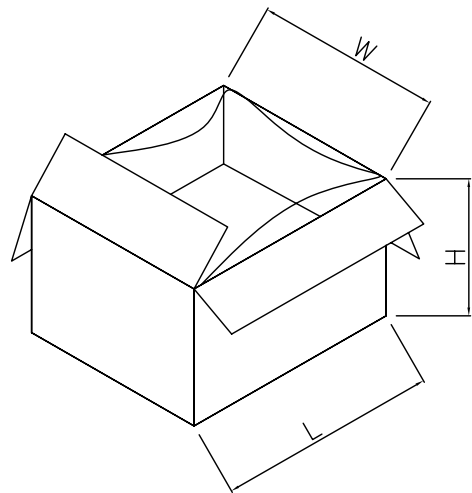
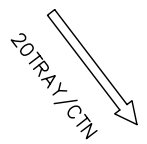
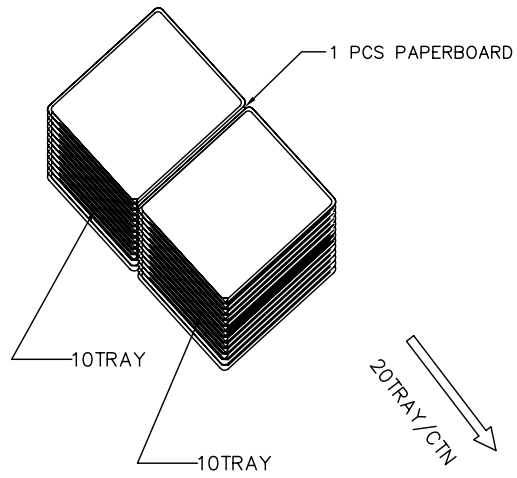

TOLERANCE .0=±0.30 .00=±0.20 .000=±0.10 ANG.=±3'		DRAWER <i>Duan</i>		<b>Astron</b> ASTRON TECHNOLOGY CORP.
UNITS : mm		CHECK <i>Slony</i>		
SCALE NONE SIZE A5		APP'D <i>Slony</i>		
SHEET 2 OF 2		PRODUCT SPEC. —		NAME DVI FEMALE 24+5PIN NO BACK SHELL DIP TYPE
REV. H				DRAW NO. R2560029-XWX-X