

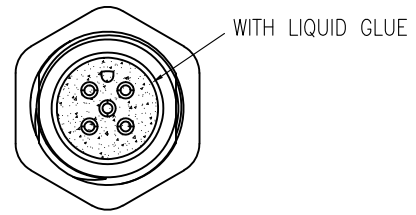

REV.	DESCRIPTION	DATE
A	RELEASE	Feb. 21, 2020

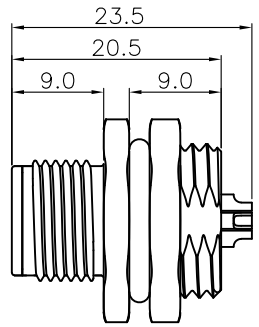
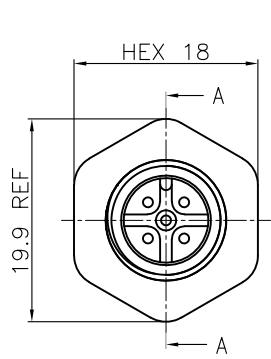

MATERIALS

1. HOUSING : NYLON 66 (UL 94V-0), BLACK.
2. CONTACT : COPPER ALLOY, GOLD FLASH PLATED.
3. SHELL : COPPER ALLOY, NICKEL PLATED.
4. O-RING : SILICONE, RED.
5. NUT : COPPER ALLOY, NICKEL (PG9 / M15 / M16).

SPECIFICATION

1. CURRENT RATING : 5A(2~5PIN), 2A(8PIN) AC/DC
2. VOLTAGE RATING : 60V AC/DC
3. CONTACT RESISTANCE : 5mΩ MAX.
4. INSULATION RESISTANCE : 100MΩ Min.
5. DIELECTRIC WITHSTANDING VOLTAGE : 500V AC r.m.s
6. OPERATING TEMPERATURE : -40°C TO +100°C.
7. DURABILITY : 500 CYCLES.
8. WATERPROOF RATE : IP-X7.

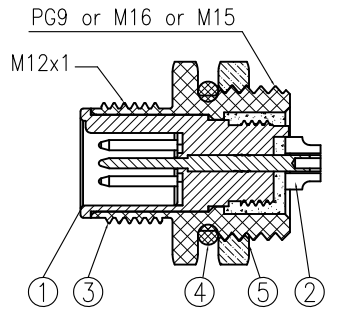

Section A-A

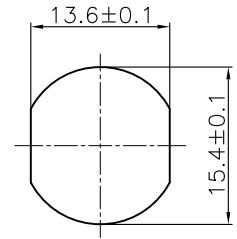

PG9 RECOMMENDED
PANEL CUT-OUT
THICKNESS 4.0 MAX.

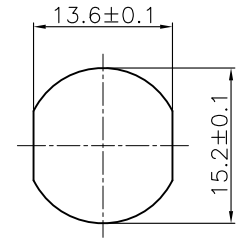

M15 RECOMMENDED
PANEL CUT-OUT
THICKNESS 4.0 MAX.

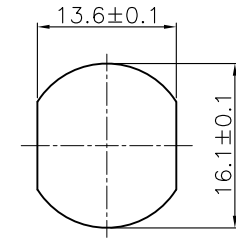

M16 RECOMMENDED
PANEL CUT-OUT
THICKNESS 4.0 MAX.

PART NUMBER INFORMATION :

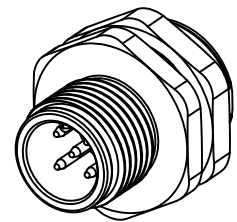
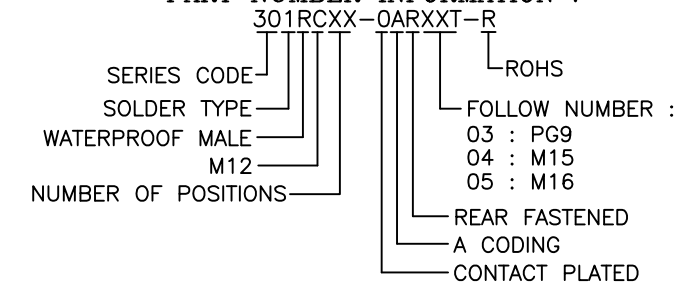

PIN ASSIGNMENTS FRONT VIEW

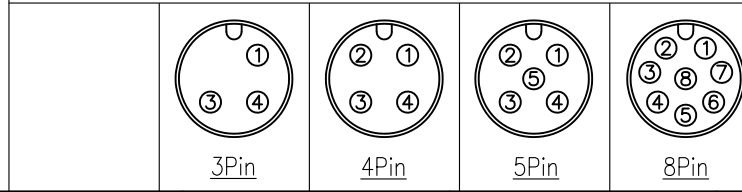

GENERAL TOLERANCE		DRAWER <i>pg</i>		Astron® ASTRON TECHNOLOGY CORP.
DIM.	.0 = ±0.30 .00 = ±0.20 .000 = ±X.XX	CHECK <i>ERF</i>	NAME	
ANG.	0° = ±5° .0° = ±3° .00° = ±X°	APP'D <i>ALAN</i>	PRODUCT SPEC.	M12 PLUG A CODE REAR FASTENED SOLDER TYPE
3rd ANGLE PROJECTION		CONFIDENTIAL		PART NO. 301RCXX-0ARXXT-R
SCALE NONE	SIZE A4	SHEET 1 OF 2	REV. A	20001 C NO.