

REV.	DESCRIPTION	DATE
A	RELEASED	May. 08, 2015
A1		Feb. 16, 2017
B	ADD PACKAGE DRAWING	Sep. 14, 2020

MATERIALS

- HOUSING : HI.-TEMPER PLASTIC (UL 94V-0), BLACK.
- TERMINAL : COPPER ALLOY,
PLATING : GOLD PLATED ON CONTACT AREA,
GOLD FLASH PLATED ON SOLDER TAILS.

SPECIFICATION

- CURRENT RATING : 0.5A MAX.
- DIELECTRIC WITHSTANDING VOLTAGE :
500V AC R.M.S. FOR 1 MINUTE.
- INSULATION RESISTANCE : 1000MΩ MIN. AT 500V DC.
- CONTACT RESISTANCE : 30mΩ MAX.
- OPERATING TEMPERATURE : -40°C TO +85°C.
- DURABILITY : 5000 CYELES.
- WATER PROOFNESS :
THIS PRODUCT IS BASED ON IPX/7 OF THE JIS STANDARD.
- INSETION FORCE : 0.6Kgf ~ 2.0Kgf
- WITHDRAWAL FORCE : 0.6Kgf ~ 2.0Kgf
- USING PLUG : ø3.5MM · 4-POLE STEREO
EARPHONE(LCH/RCH/GND/MIC)
- BODY WITH O-RING'S SEAL AREA BURRS IS 0.05mm MAX.

PART NUMBER INFORMATION :

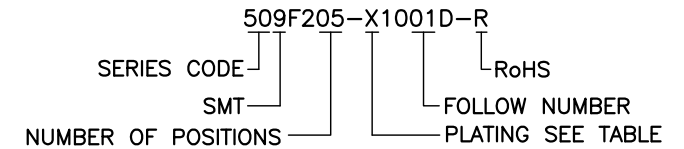

DESCRIPTION OF PLATING ON TERMINALS			
NO.	EXPLAIN	NO.	EXPLAIN
0	GOLD FLASH	3	GOLD 15u"
6	GOLD 30u"		
GENERAL TOLERANCE		DRAWER	
DIM.	.0 = ±0.25 .00 = ±0.15 .000 = ±0.05	LJI	
ANG.	0° = ±3' .0° = ±X' .00° = ±X'	CHECK	
3rd ANGLE PROJECTION		APP'D	
UNITS : mm		PACKAGE SPEC.	
SCALE	SIZE	SHEET	REV.
NONE	A4	1 OF 2	B
CONFIDENTIAL		PART NO.	
		509F205-X1001D-R	
		C NO.	
		08026	

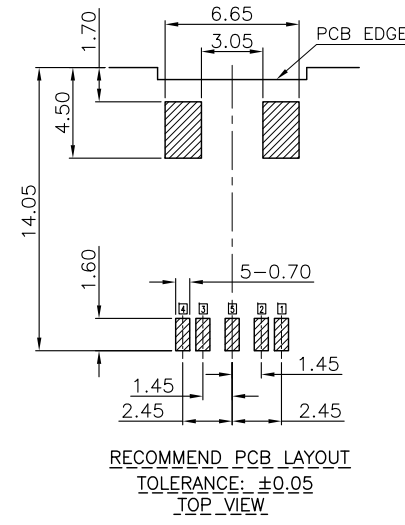
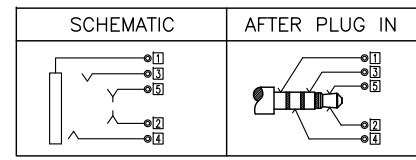
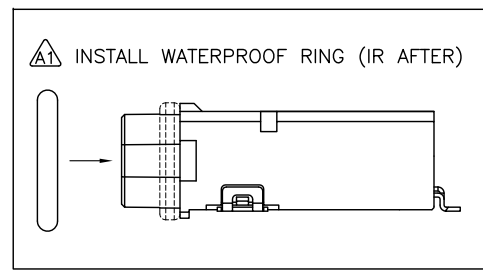
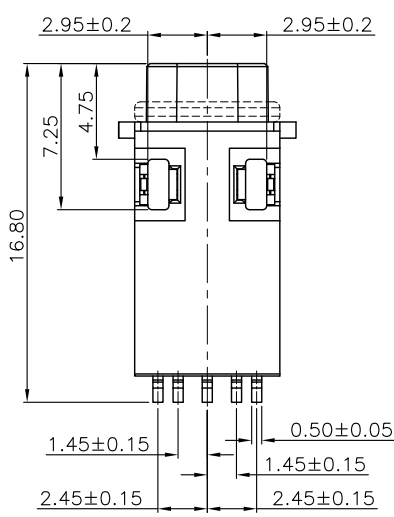
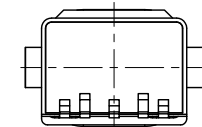
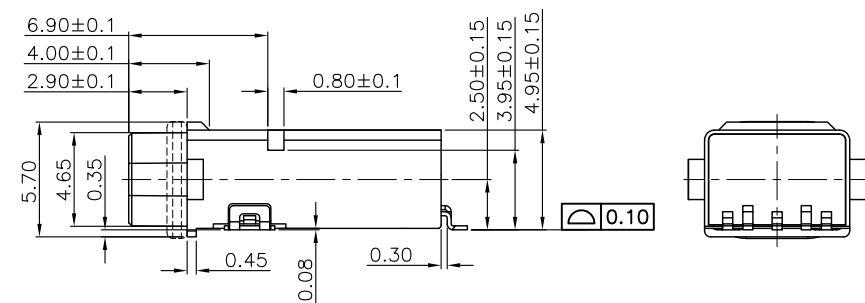
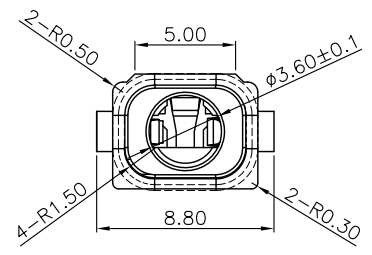
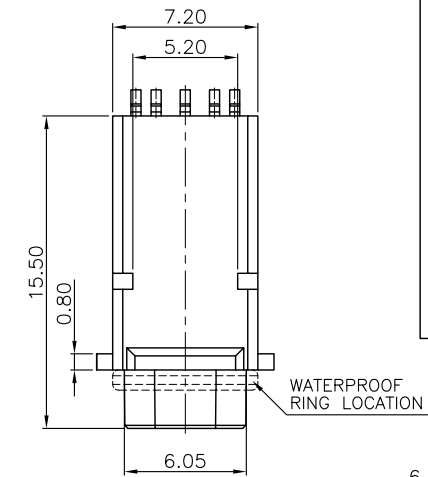
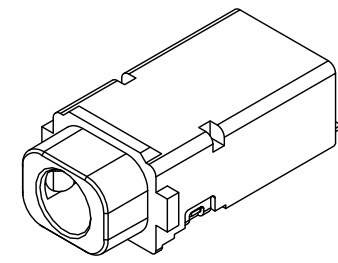
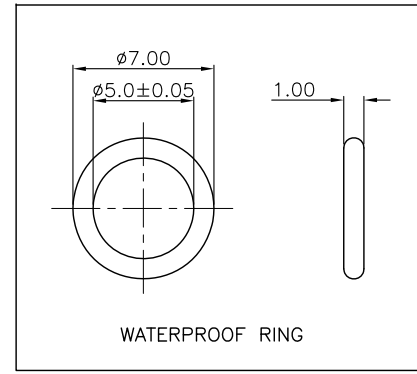

REV.	DESCRIPTION	DATE
A	RELEASED	May 08, 2015
A1		Feb 16, 2017
B	ADD PACKAGE DRAWING	Sep. 14, 2020

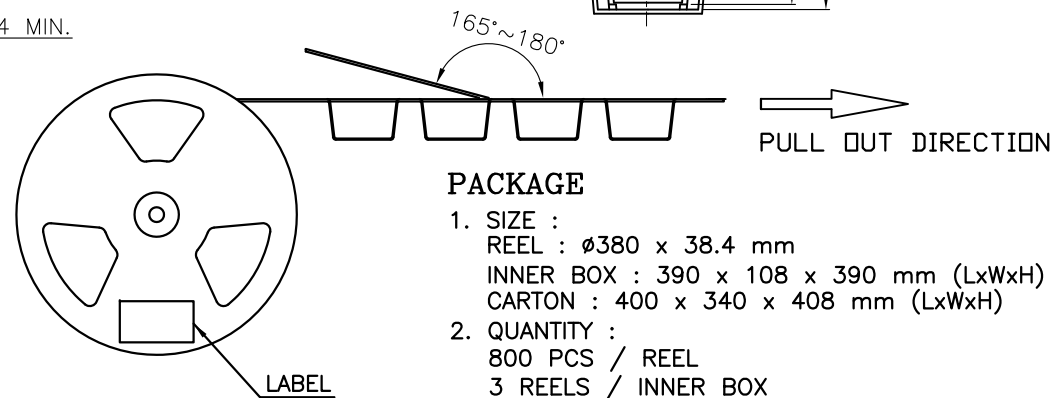
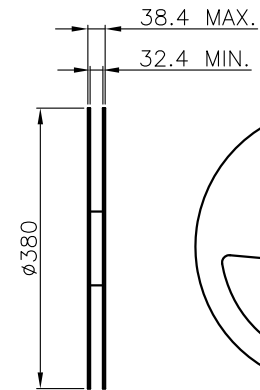
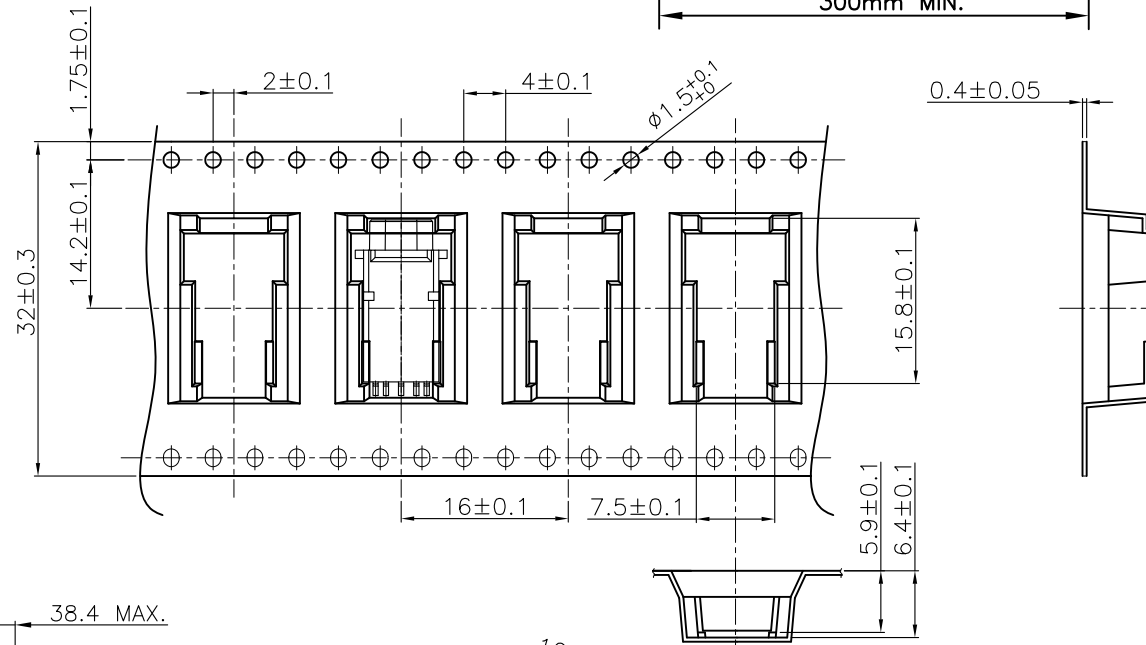
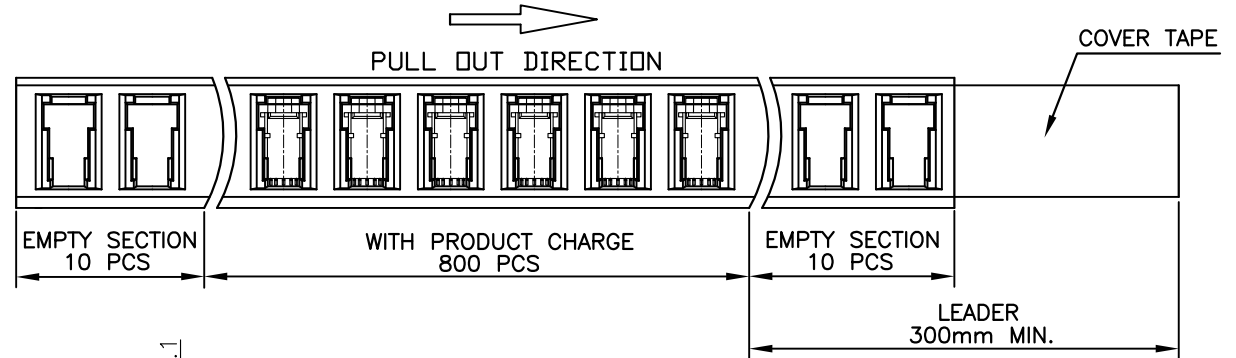

PACKAGE

1. SIZE :
 REEL : $\phi 380 \times 38.4$ mm
 INNER BOX : $390 \times 108 \times 390$ mm (LxWxH)
 CARTON : $400 \times 340 \times 408$ mm (LxWxH)
2. QUANTITY :
 800 PCS / REEL
 3 REELS / INNER BOX
 3 INNER BOXES / CARTON = 7,200 PCS

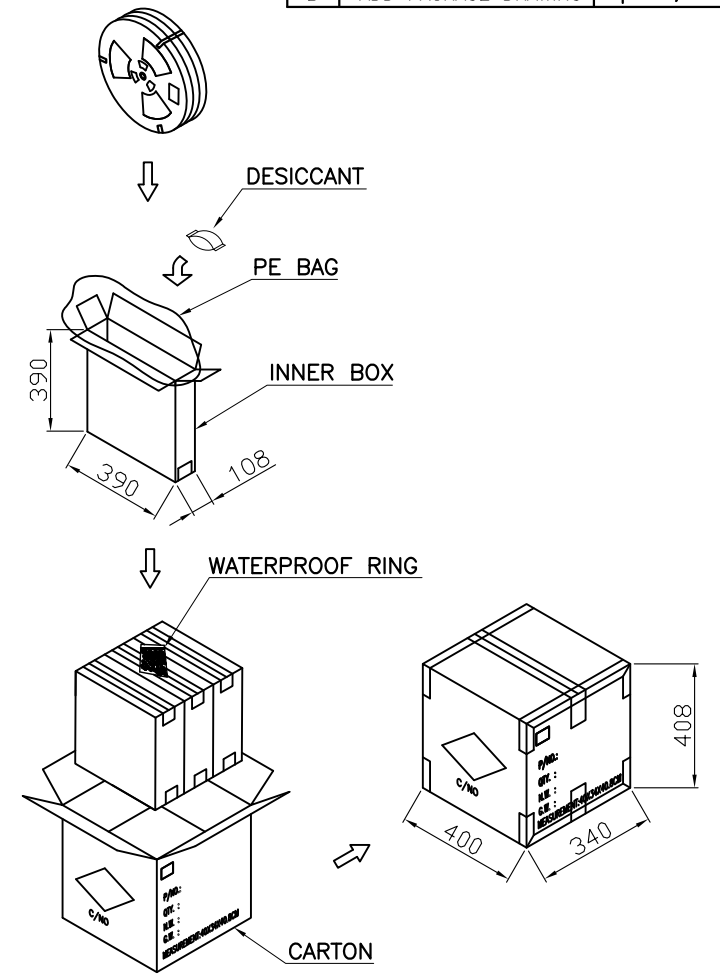

GENERAL TOLERANCE	DRAWER	 ASTRON TECHNOLOGY CORP.
DIM. .0 = ± 0.25 .00 = ± 0.15 .000 = ± 0.05	DRAWER <i>LJI</i> CHECK <i>ERP</i>	
ANG. 0° = $\pm 3'$.0° = $\pm X'$.00° = $\pm X'$	APP'D <i>ALAN</i> PACKAGE SPEC. -	
3rd ANGLE PROJECTION	CONFIDENTIAL	NAME WATERPROOF PHONE JACK $\phi 3.5$ mm
SCALE NONE SIZE A4	SHEET 2 OF 2 REV. B	PART NO. 509F205-X1001D-R
		C NO. 08026