

REV.	DESCRIPTION	DATE
1	PRELIMINARY	FEB. 12, 2019



MATERIALS

1. HOUSING : LCP (UL 94V-0), BLACK.
2. CONTACT : PHOSPHOR BRONZE, GOLD FLASH PLATED OVER NICKEL.

SPECIFICATION

1. CURRENT RATING : 0.5A
2. CONTACT RESISTANCE : 30mΩ MAX.
3. INSULATION RESISTANCE : 1000MΩ Min,
4. DIELECTRIC WITHSTANDING VOLTAGE : 300V AC R.M.S. FOR ONE MINUTE.
5. OPERATING TEMPERATURE : -40°C ~ +105°C.
6. SI FOR USB 3.1 GEN2 & PCI EXPRESS 3.0.

PART NUMBER INFORMATION :

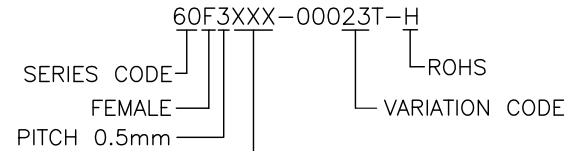

NUMBER OF POSITIONS
 020 : 20PIN (2X10PIN)
 030 : 30PIN (2X15PIN)

PIN	DIM.		
	A	B	C
20	4.50	5.50	6.50
30	7.00	8.00	9.00

Astron®
ASTRON TECHNOLOGY CORP.

NAME: BOARD TO BOARD CONNECTOR
 PITCH : 0.50mm, SMT TYPE, FEMALE
 MATED HEIGHT : 1.5mm

PART NO. 60F3XXX-00023T-H

12028 C NO.

GENERAL TOLERANCE		DRAWER	BNDY	
DIM.	0. = ±0.50 .0 = ±0.30 .00 = ±0.20 .000 = ±0.10	CHECK	ERP	
ANG.	.0° = ±5° .00° = ±1°	APP'D	ALAN	
3rd ANGLE PROJECTION		PRODUCT SPEC.	-	
UNITS : mm [inch]		CONFIDENTIAL		
SCALE	SIZE	SHEET	REV.	
NONE	A4	1 OF 3	1	

MALE	60M3XXX-0XX20T-H	1.5mm
	P/N	MATED HEIGHT

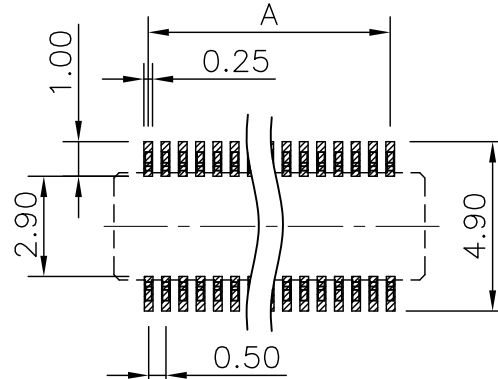
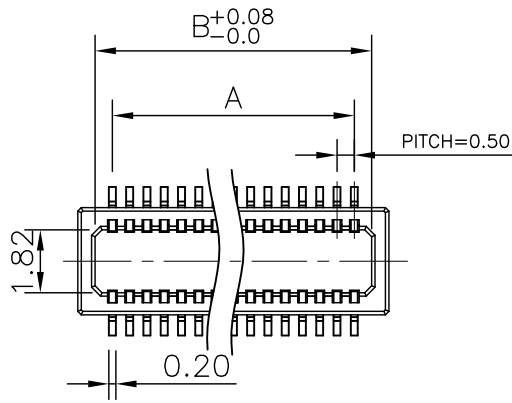

RECOMMEND P.C.B. LAYOUT
 TOLERANCE : ±0.05
 TOP VIEW

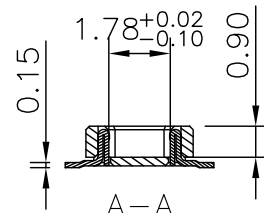
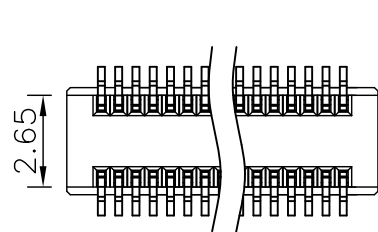
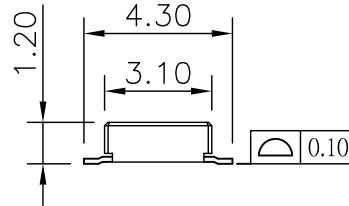
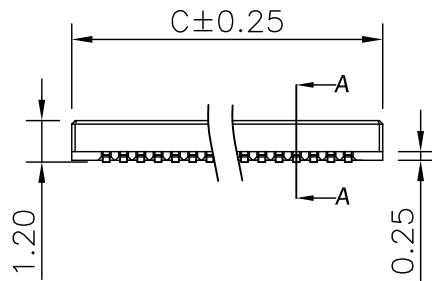

REV.	DESCRIPTION	DATE
1	PRELIMINARY	FEB. 12, 2019

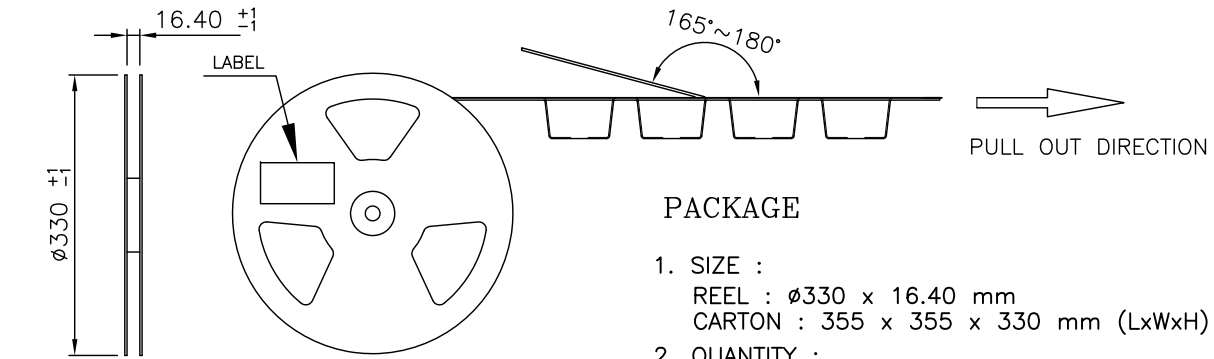
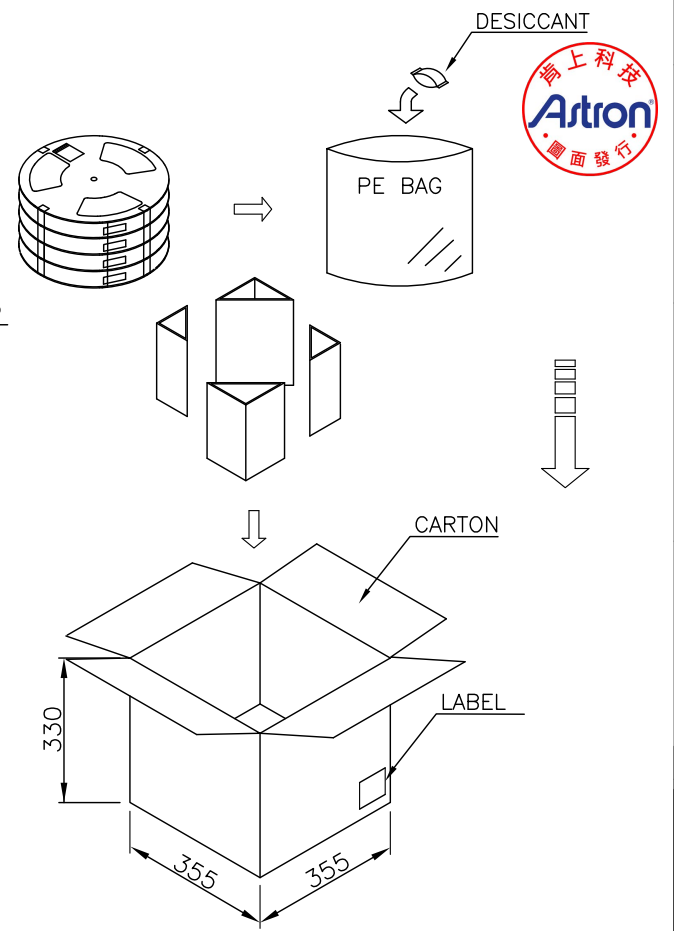
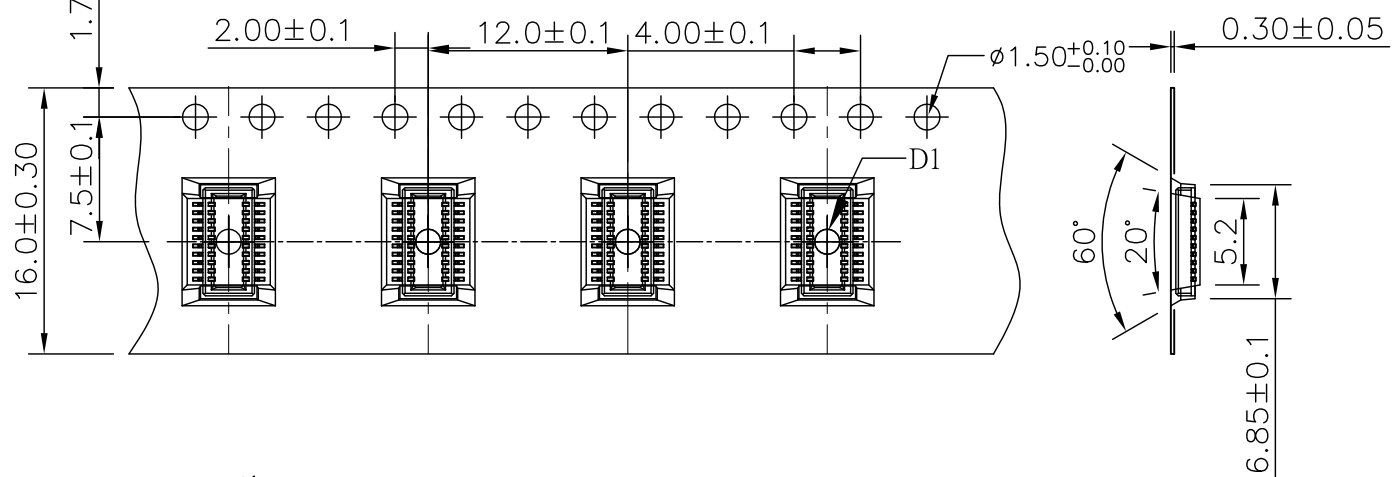
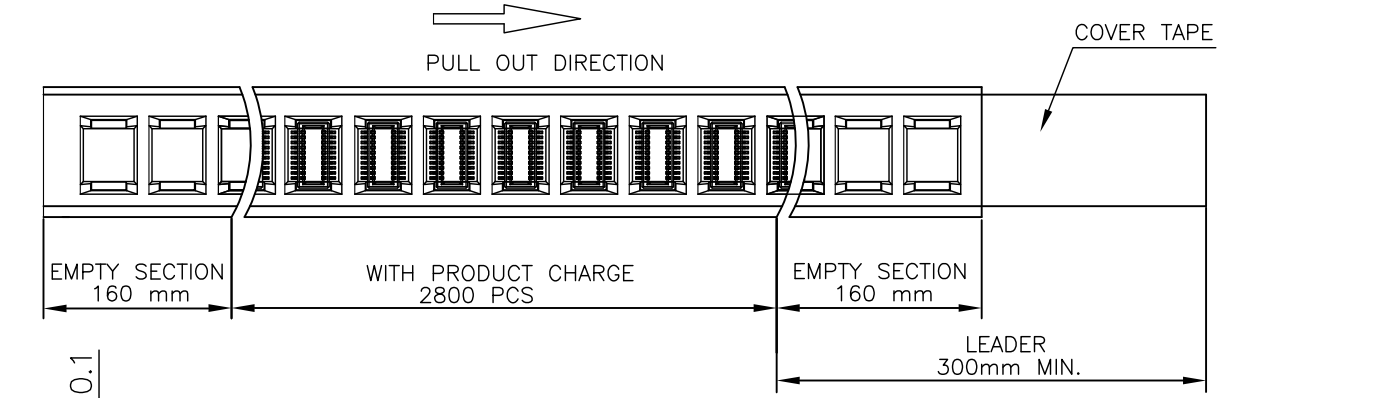

PACKAGE

1. SIZE :
 REEL : $\phi 330 \times 16.40$ mm
 CARTON : $355 \times 355 \times 330$ mm (LxWxH)
2. QUANTITY :
 2800 PCS / REEL
 14 REEL / CARTON = 39200 PCS
3. APPLICABLE DOCUMENTS : EIA-481-C
4. PACKAGE FOR 20PIN

GENERAL TOLERANCE		DRAWER <i>BINDY</i>		 ASTRON TECHNOLOGY CORP.	
DIM.	0. = ±0.50 .0 = ±0.35 .00 = ±0.25 .000 = ±0.15	CHECK <i>ERP</i>			
ANG.	.0° = ±3° .00° = ±1°	APP'D <i>ALAN</i>		BOARD TO BOARD CONNECTOR PITCH : 0.50mm, SMT TYPE FEMALE MATED HEIGHT : 1.5mm	
3rd ANGLE PROJECTION		PACKAGE SPEC. -		PART NO. 60F3XXX-00023T-H	
UNITS : mm [inch]		CONFIDENTIAL		12028	
SCALE NONE	SIZE A4	SHEET 2 OF 3	REV. 1	C NO.	

REV.	DESCRIPTION	DATE
1	PRELIMINARY	FEB. 12, 2019

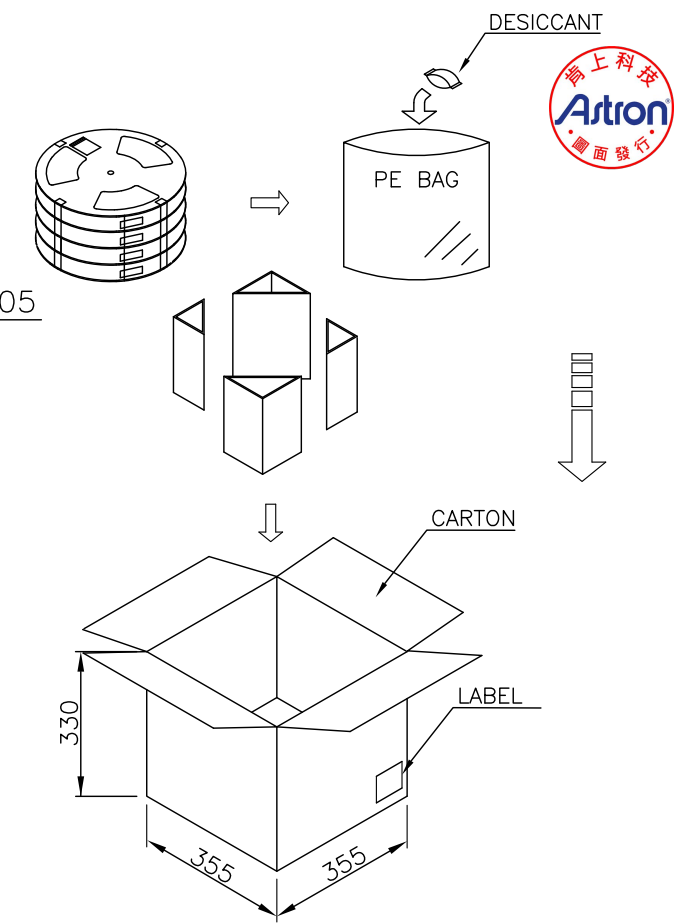
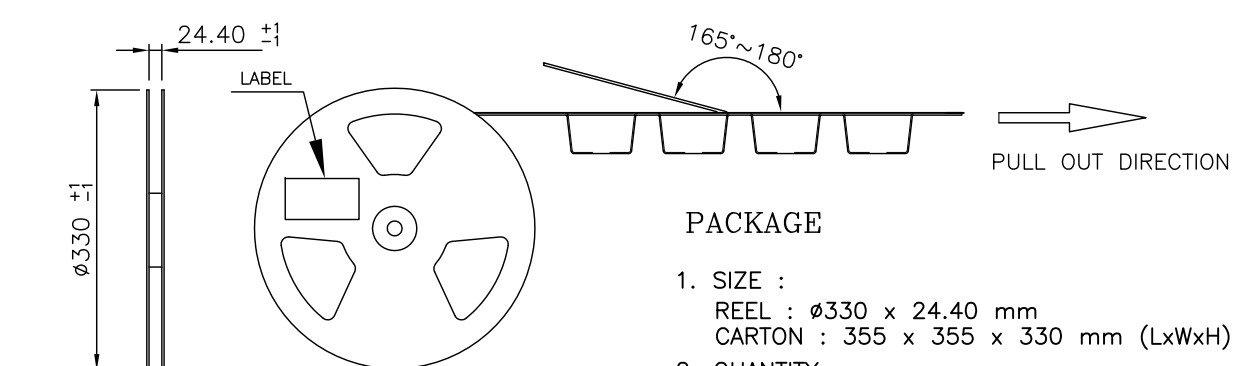
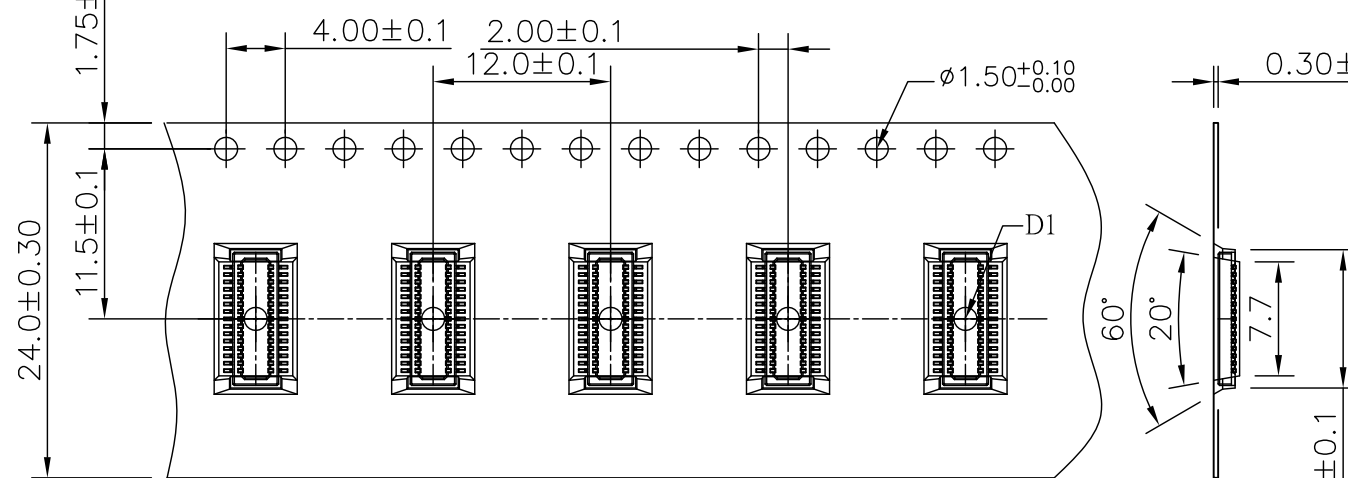
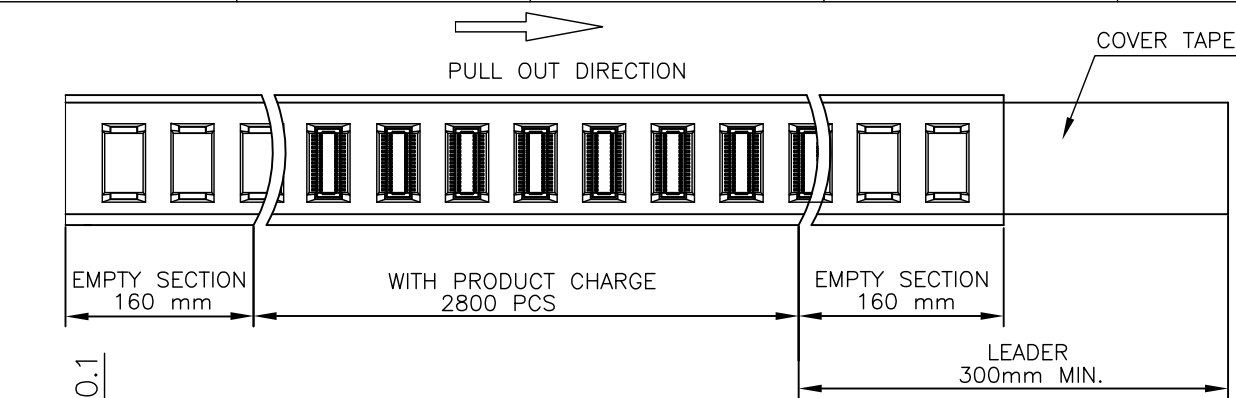

PACKAGE

1. SIZE :
 REEL : $\phi 330 \times 24.40$ mm
 CARTON : $355 \times 355 \times 330$ mm (LxWxH)
2. QUANTITY :
 2800 PCS / REEL
 11 REEL / CARTON = 30800 PCS
3. APPLICABLE DOCUMENTS : EIA-481-C
4. PACKAGE FOR 30PIN

GENERAL TOLERANCE		DRAWER <i>BINDY</i>		 ASTRON TECHNOLOGY CORP.	
DIM.	0. = ± 0.50 .0 = ± 0.35 .00 = ± 0.25 .000 = ± 0.15	CHECK <i>ERP</i>	APP'D <i>ALAN</i>		
ANG.	.0° = $\pm 3'$.00° = $\pm 1'$	PACKAGE SPEC.	BOARD TO BOARD CONNECTOR PITCH : 0.50mm, SMT TYPE FEMALE MATED HEIGHT : 1.5mm		
3rd ANGLE PROJECTION		CONFIDENTIAL		PART NO.	12028
UNITS : mm [inch]	SCALE NONE	SIZE A4	SHEET 3 OF 3	REV. 1	C NO.