

REV.	DESCRIPTION	DATE
1	PRELIMINARY	FEB. 13, 2019



MATERIALS

1. HOUSING : LCP (UL 94V-0), BLACK.
2. CONTACT : PHOSPHOR BRONZE, GOLD FLASH PLATED OVER NICKEL.

SPECIFICATION

1. CURRENT RATING: 0.5A
2. CONTACT RESISTANCE : 30mΩ MAX.
3. INSULATION RESISTANCE : 1000MΩ Min,
4. DIELECTRIC WITHSTANDING VOLTAGE : 300V AC R.M.S. FOR ONE MINUTE.
5. OPERATING TEMPERATURE : -40°C ~ +105°C.
6. SI FOR USB 3.1 GEN2 & PCI EXPRESS 3.0.

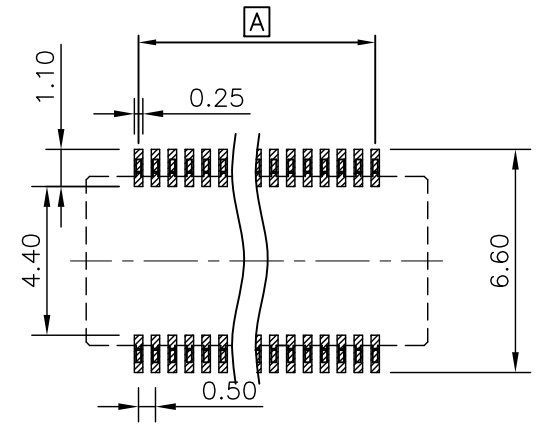
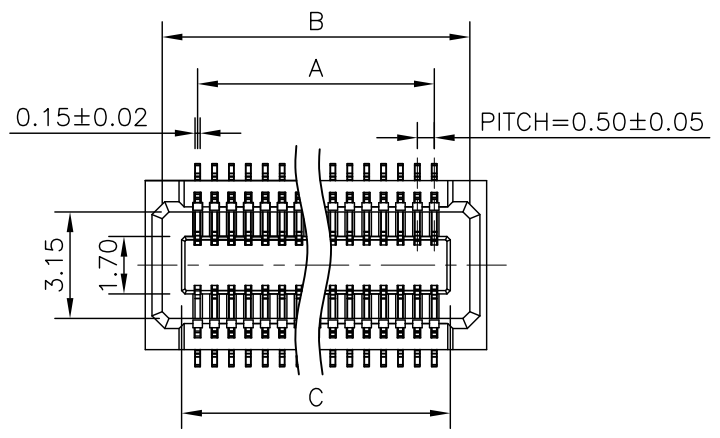

RECOMMEND P.C.B. LAYOUT
TOLERANCE : ±0.05
TOP VIEW

PART NUMBER INFORMATION :

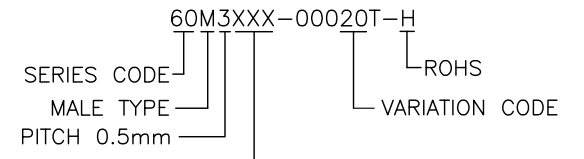

NUMBER OF POSITIONS
020 : 20PIN (2X10PIN)
030 : 30PIN (2X15PIN)

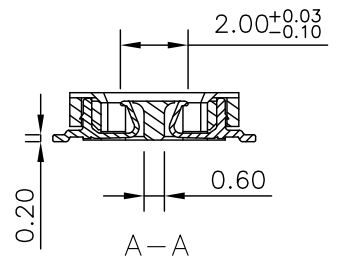
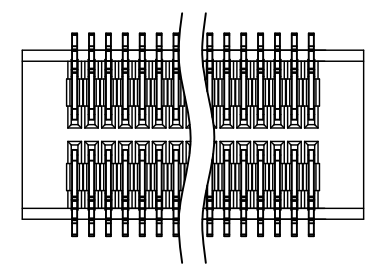
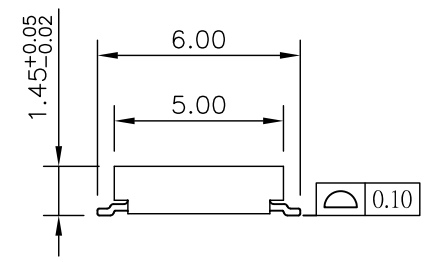
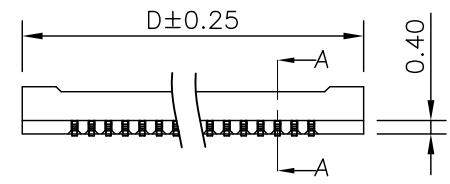

PIN	DIM.			
	A	B	C	D
20	4.50	6.60	5.45	7.60
30	7.00	9.10	7.95	10.10

GENERAL TOLERANCE		DRAWER
DIM.	0. = ±0.50 .0 DIM = ±0.30 .00 = ±0.20 .000 = ±0.10	BINDY
ANG.	.0° = ±5° .00° = ±1°	CHECK
3rd ANGLE PROJECTION		APP'D
UNITS : mm [inch]		ALAN
SCALE	NONE	PRODUCT SPEC.
SIZE	A4	
SHEET	1 OF 3	CONFIDENTIAL
REV.	1	

Astron
ASTRON TECHNOLOGY CORP.

NAME BOARD TO BOARD CONNECTOR
PITCH : 0.50mm, SMT TYPE, MALE
MATED HEIGHT : 1.5mm

PART NO. 60M3XXX-00020T-H

FEMALE	60F3XXX-0XX23T-H	1.5mm	SCALE	SIZE	SHEET	REV.	12028	C NO.
	P/N	MATED HEIGHT	NONE	A4	1 OF 3	1		

REV.	DESCRIPTION	DATE
1	PRELIMINARY	FEB. 13, 2019

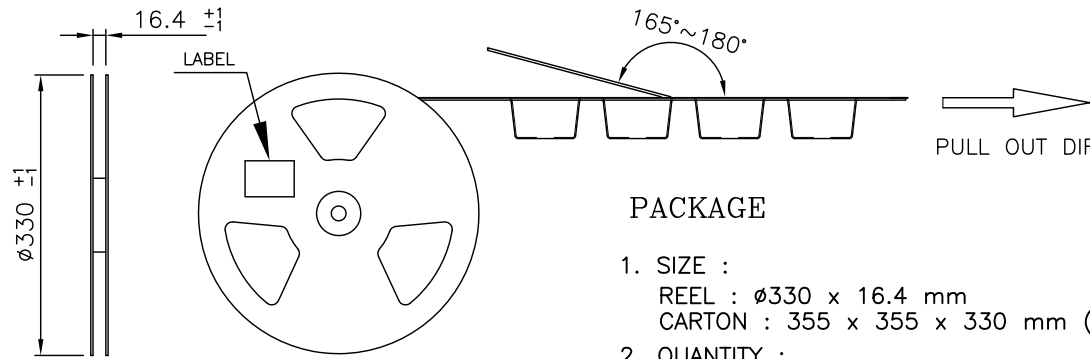
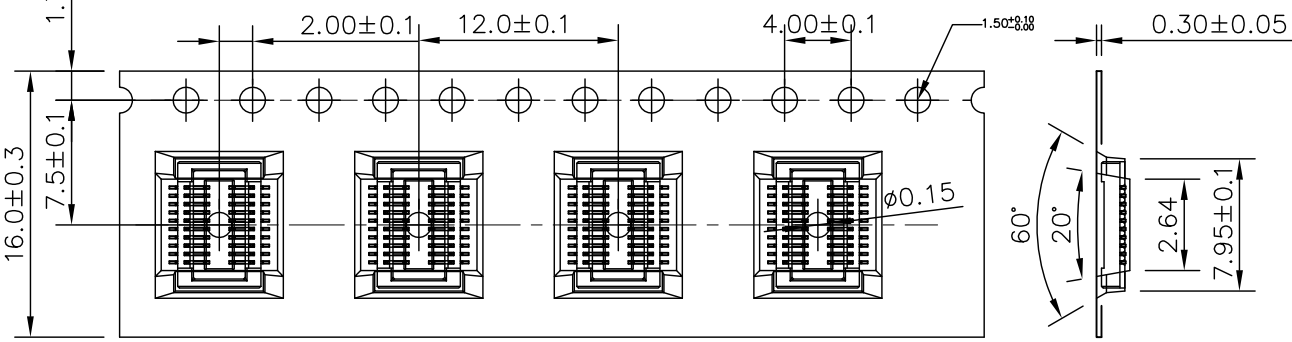
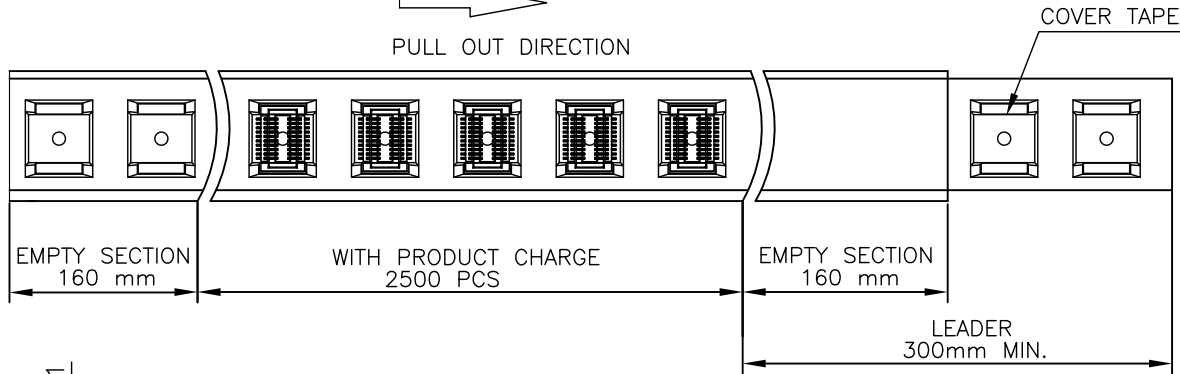

PACKAGE

1. SIZE :
 REEL : $\phi 330 \times 16.4$ mm
 CARTON : $355 \times 355 \times 330$ mm (LxWxH)
2. QUANTITY :
 2500 PCS / REEL
 14 REEL / CARTON = 35000 PCS
3. APPLICABLE DOCUMENTS : EIA-481-C
4. PACKAGE FOR 20PIN

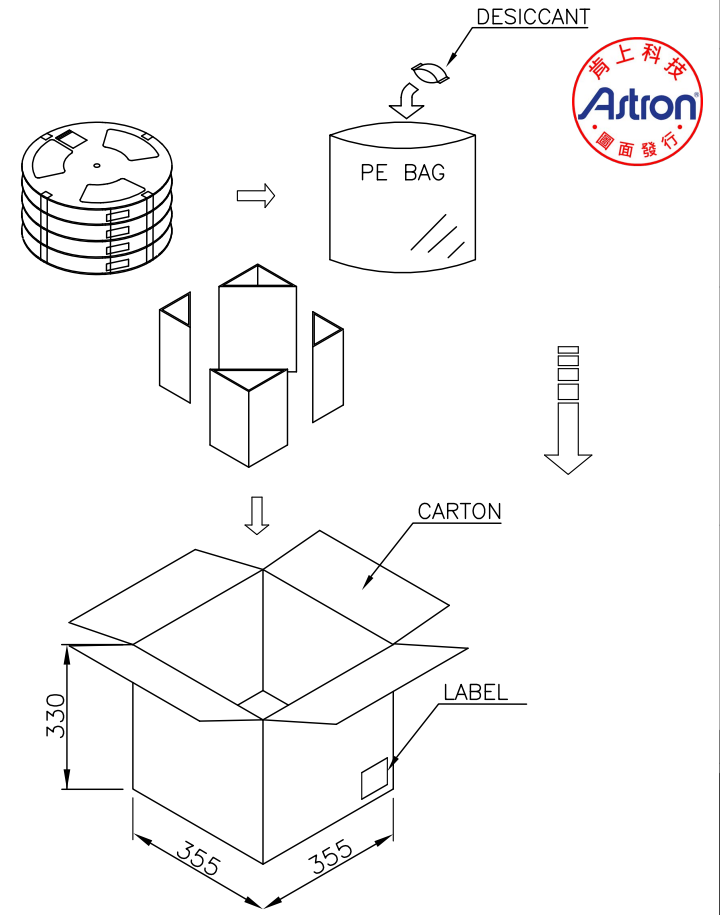

GENERAL TOLERANCE		DRAWER <i>BINDY</i>		 ASTRON TECHNOLOGY CORP.	
DIM.	0. = ±0.50 .0 = ±0.35 .00 = ±0.25 .000 = ±0.15	CHECK <i>ERIC</i>	APP'D <i>ALAN</i>		
ANG.	.0° = ±3° .00° = ±1°	PACKAGE SPEC.	CONFIDENTIAL		PART NO. 60M3XXX-00020T-H
3rd ANGLE PROJECTION		SCALE NONE	SIZE A4	SHEET 2 OF 3	REV. 1
UNITS : mm [inch]		12028		C NO.	

REV.	DESCRIPTION	DATE
1	PRELIMINARY	FEB. 13, 2019

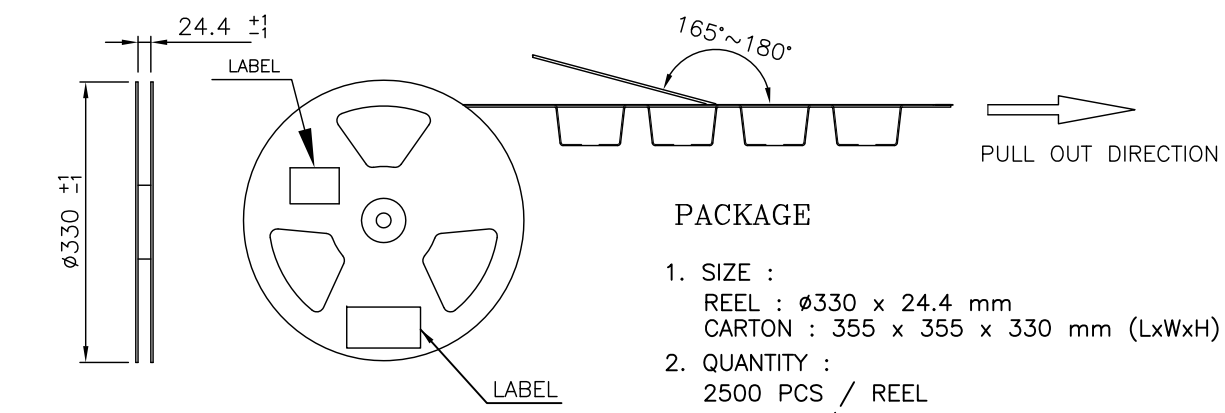
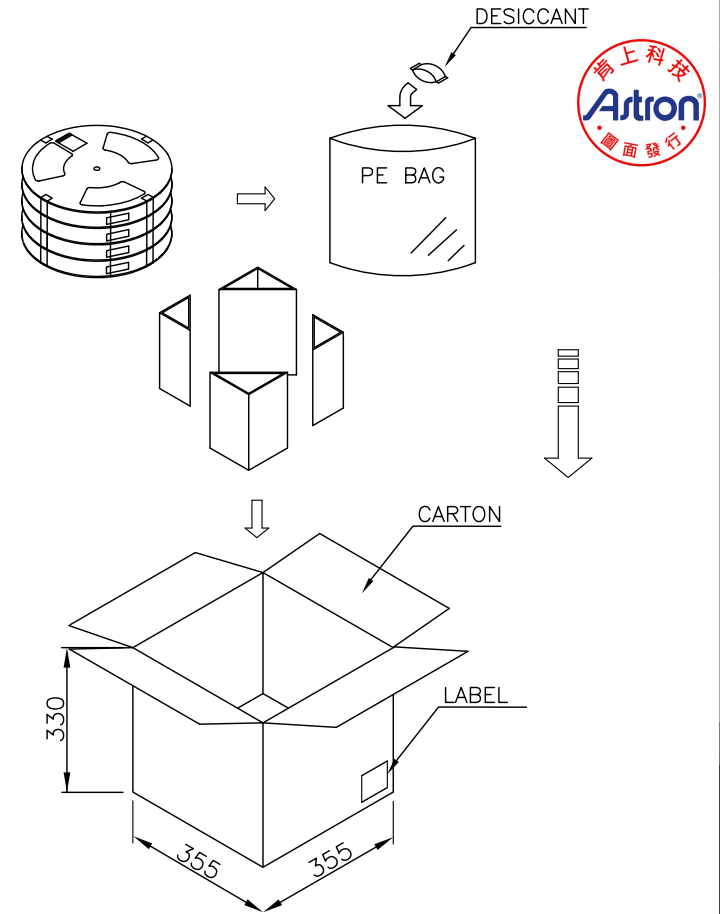
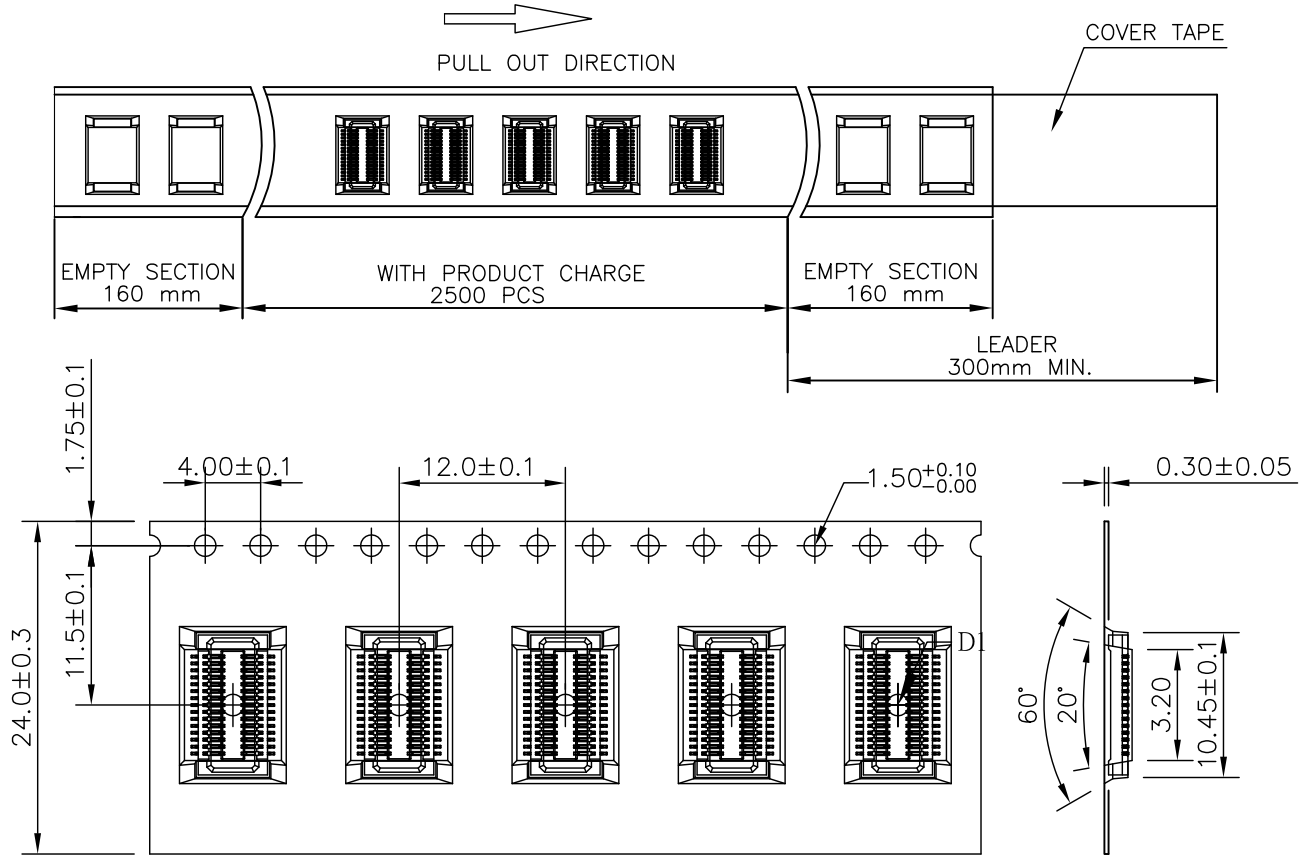

PACKAGE

1. SIZE :
 REEL : $\phi 330 \times 24.4$ mm
 CARTON : $355 \times 355 \times 330$ mm (LxWxH)
2. QUANTITY :
 2500 PCS / REEL
 11 REEL / CARTON = 27500 PCS
3. APPLICABLE DOCUMENTS : EIA-481-C
4. PACKAGE FOR 30PIN

GENERAL TOLERANCE		DRAWER <i>BINDY</i>		 ASTRON TECHNOLOGY CORP.	
DIM.	0. = ± 0.50	CHECK <i>ERP</i>	APP'D <i>ALAN</i>		
	.0 = ± 0.35	PACKAGE SPEC. -	CONFIDENTIAL	PITCH : 0.50mm, SMT TYPE, MALE	
ANG.	.0° = $\pm 3'$			MATED HEIGHT : 1.5mm	
	.00° = $\pm 1'$			PART NO. 60M3XXX-00020T-H	
3rd ANGLE PROJECTION					
UNITS : mm [inch]					
SCALE NONE	SIZE A4	SHEET 3 OF 3	REV. 1	12028	C NO.