

REV.	DESCRIPTION	DATE
A	N20'08008	Aug.26, 2020

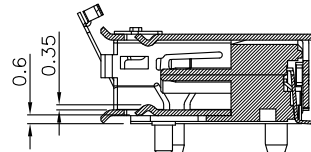

SECTION A-A

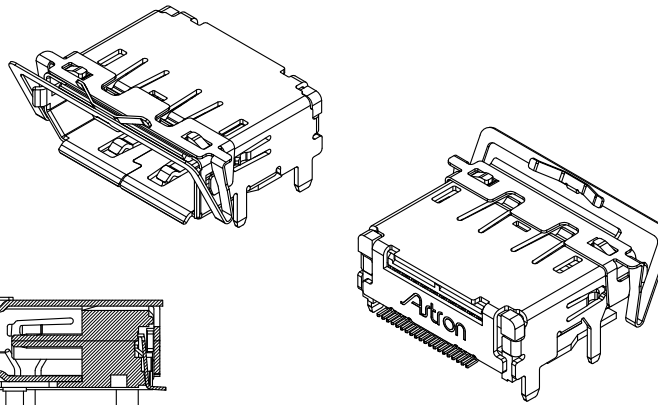
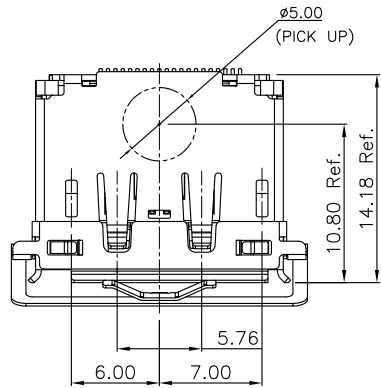
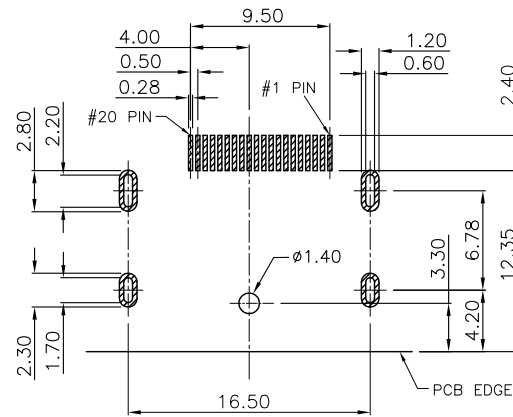
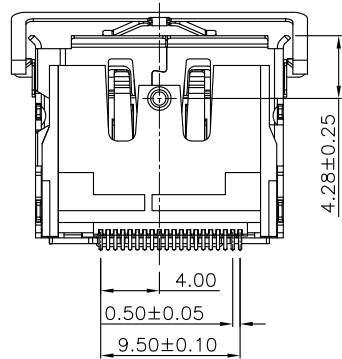
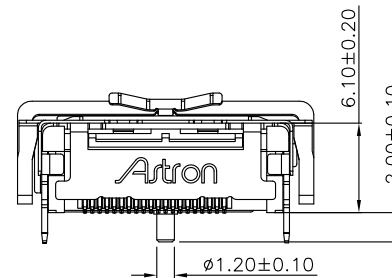
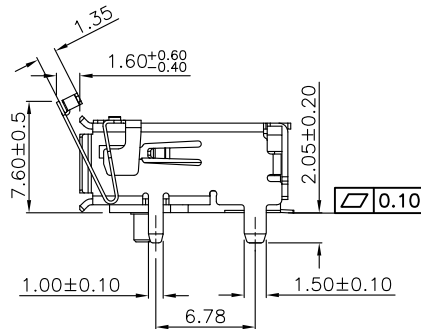
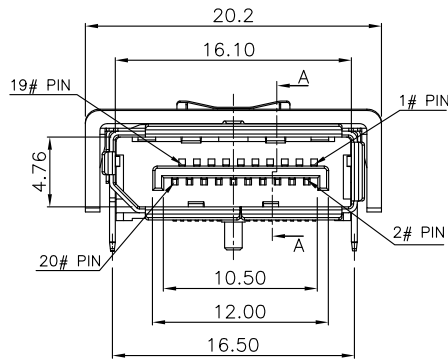

RECOMMENDED P.C.B LAYOUT
TOLERANCE ±0.05
TOP VIEW

MATERIALS

- HOUSING : LCP (UL 94V-0), BLACK.
- TERMINAL : COPPER ALLOY, t=0.20mm, GOLD FLASH. UNDER NICKEL PLATING.
- SHELL : COPPER ALLOY, t=0.4mm, NICKEL PLATING.
- EMI SPRING : STAINLESS STEEL, t=0.20mm.

SPECIFICATION

- CURRENT RATING : 0.5A MAX.
- DIELECTRIC WITHSTANDING VOLTAGE : 500V AC R.M.S. FOR 1 MINUTE.
- INSULATION RESISTANCE : 100MΩ MIN. AT 500V DC.
- CONTACT RESISTANCE : 30mΩ MAX.
- OPERATING TEMPERATURE : -40°C TO +85°C.
- DURABILITY : 10,000 CYCLES.
- INSERTION FORCE : 4.5kgf MAX.
- WITHDRAWAL FORCE : 1.0kgf MIN.
- SOLDERING HEAT RESISTANCE REFLOW SOLDERING 260°C/5sec.

PART NUMBER INFORMATION

699FA20-0N086D-H

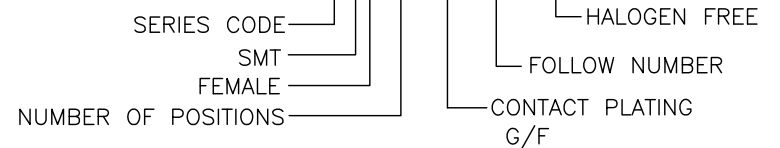

TOLERANCE .0=±0.25 .00=±0.15 .000=±0.05 ANG.=±3°	DRAWER <i>Chen</i> CHECK <i>Stony</i> APP'D <i>Stony</i>	 ASTRON TECHNOLOGY CORP. NAME DISPLAY PORT R/A SMT TYPE. FEMALE. WITH SPRING
 UNITS : mm SCALE NONE SIZE A4 SHEET 1 OF 2 REV. A	PRODUCT SPEC. — DRAW NO. 699FA20-0N086D-H	

REV.	DESCRIPTION	DATE
A	N20'08008	Aug.26, 2020

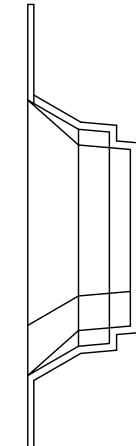
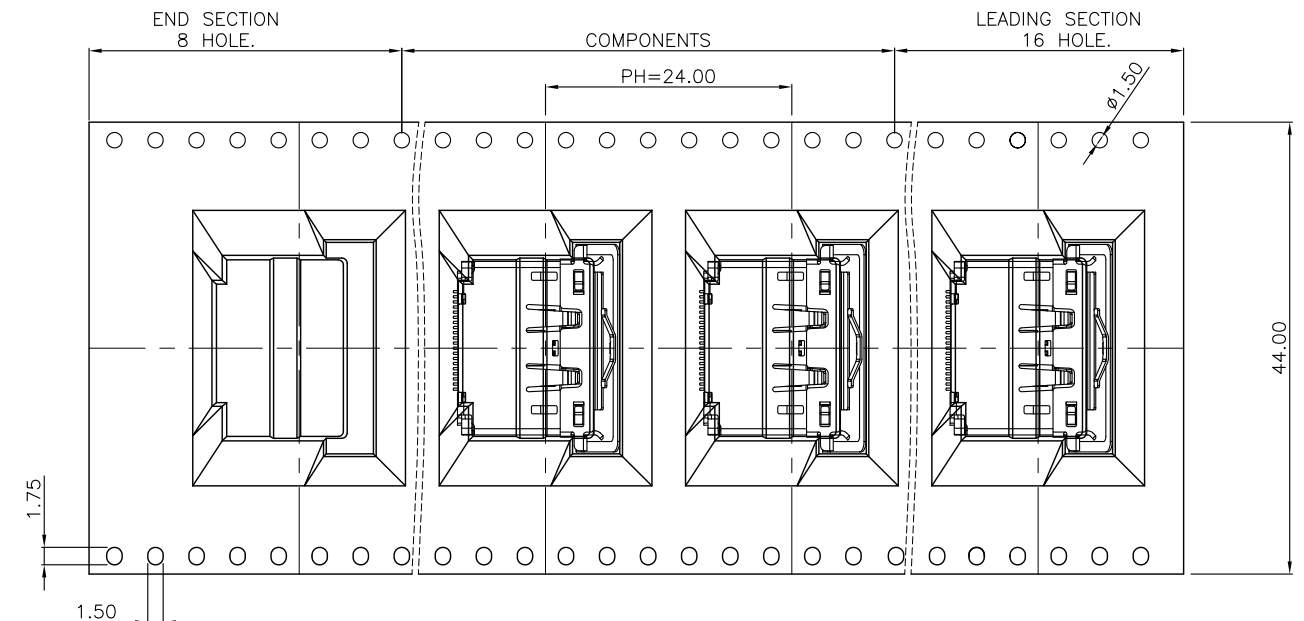

PULL OUT DIRECTION



**TAPE & REEL PACKAGE :
SIZE**

- 1. REEL : ø380 X 44 mm
- CARTON : L=400mm, W=400mm, H=270mm

QUANTITY

- 1. 300 PCS PER REEL.
- 2. 5 REEL PER CARTON (1,500 PCS PER CARTON).

MATERIALS

- 1. CARRIER TAPE: POLYSTYREN (PS)
- 2. COVER TAPE: POLYSTYREN (PS)
- 3. REEL: POLYSTYREN (PS)
- 4. APPLICABLE DOCUMENTS : EIA-481-C

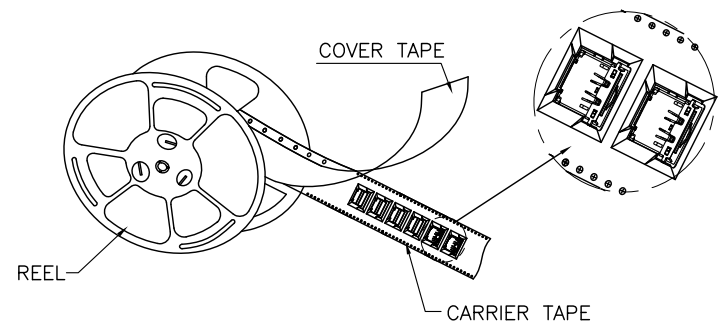
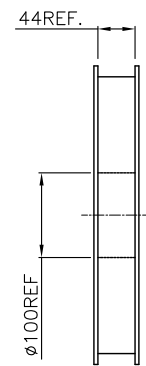
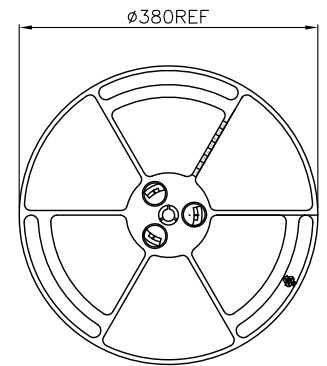

REEL FOR CARRIER TAPE

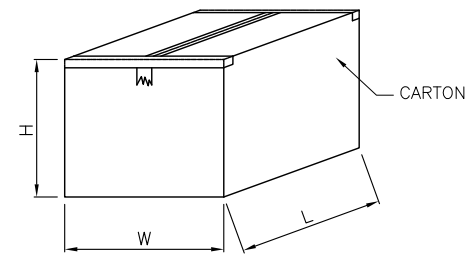

<p>TOLERANCE</p> <p>.0=±0.25</p> <p>.00=±0.15</p> <p>.000=±0.05</p> <p>ANG.=±3'</p>	<p>DRAWER</p> <p><i>Chen</i></p>	<p>Astron</p> <p>ASTRON TECHNOLOGY CORP.</p>
	<p>CHECK</p> <p><i>Stony</i></p>	
<p>UNITS : mm</p> <p>SCALE NONE</p> <p>SIZE A4</p>	<p>APP'D</p> <p><i>Stony</i></p>	<p>DISPLAY PORT R/A SMT TYPE.</p> <p>FEMALE. WITH SPRING</p>
	<p>SHEET 2 OF 2</p>	<p>REV. A</p>